

Flow Control Valve

Model MN-770-U

Hydraulically operated, flow control valve that maintains a pre-set maximum flow, regardless of fluctuating demand or varying system pressure.

Bermad 700 Series valves are hydraulic, pilot operated, oblique pattern, globe valves with a seat assembly and double chamber unitized actuator that can be disassembled from the body as a separate integral unit.

The valve's hydrodynamic body is designed for unobstructed flow path and provides excellent and highly effective modulation capacity for high differential pressure applications.

The 700 Series operate under difficult operating conditions with minimal cavitation and noise. They are made of the highest quality materials suitable for different mining applications.



Features and Benefits

- Hydraulic flow sensor
 - No moving parts. No electronic components.
 - No need for flow straightening
- Designed to stand up to the toughest conditions
 - Tamper resistant
 - Excellent anti-cavitation properties
 - High stability and accuracy
 - Drip tight sealing
- Double chamber actuator design
 - Protected diaphragm
 - Provide rapid response to sudden changes in system conditions
 - Simplified maintenance as it can be removed as a single unit. In-line serviceable
- Flexible design - Easy addition of features
- Optional V-Port Throttling Plug - Allows for low flow stability
- Obstacle free flow path

Major Additional Features

- ON/OFF Solenoid control - **770 - 55 - U**
- Solenoid control & check feature - **770 - 25**
- Independent flow check - **770 - 2S**
- Hydraulic check valve - **770 - 20**
- High sensitive pilot - **770 - 12 - U**
- Pressure Reducing - **772 - U**
- Level & flow control valve - **757 - U**
- Pump & flow control valve - **747 - U**
- Pump recirculation & flow control valve - **749 - U**

See relevant BERMAD publications

List of Components:

- [1] Flow Controlled Valve 770
- [2] Strainer 70F
- [3] Combination Air Valve C70

Typical Installation

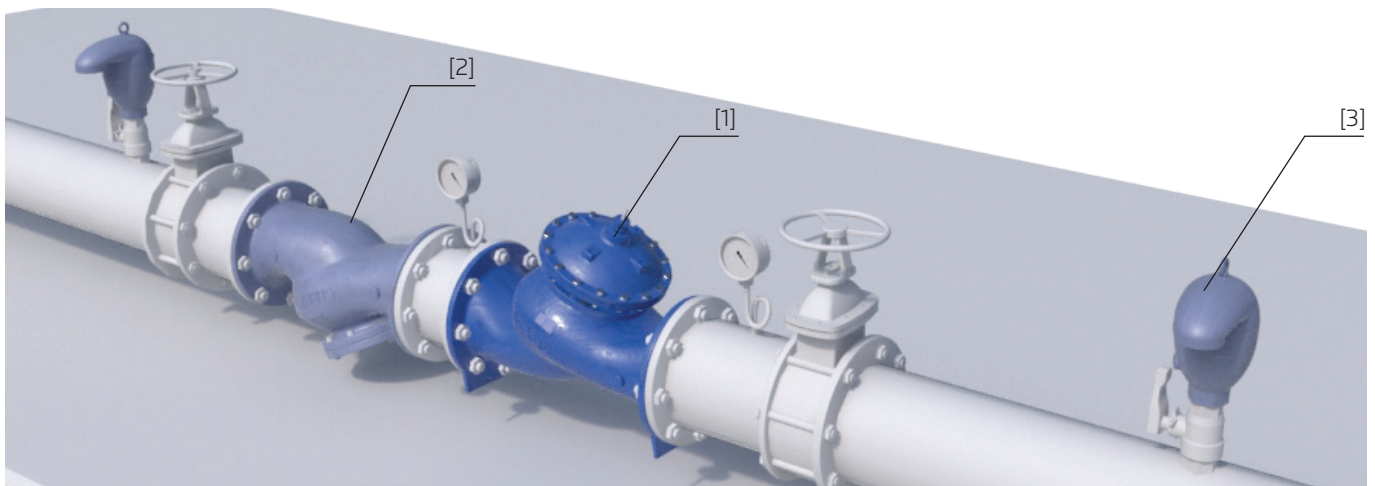



Control Schematic (*)

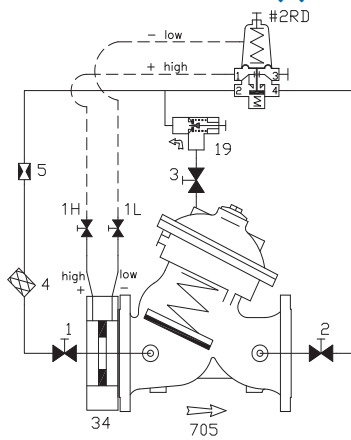

- Standard Configuration**
- 1 2W Isolation Valve
 - 1L/1H 2W Isolation Valve
 - 2 2W Isolation Valve
 - 3 2W Isolation Valve
 - 4 Control Filter
 - 5 Restriction Orifice
 - 19 Speed Control
 - 34 Orifice Plate
 - #2RD 2W Flow Control Pilot

- Additional features (OPTIONAL)**
- V V-Port Plug
 - F Large Control Filter
 - F1 Extra Large Control Filter
 - 6 Pressure Gauge
 - I Visual Position Indicator
 - S Electric Limit Switch
 - Q Position Transmitter 4-20 mA

(*) As a reference only. Components may vary based on valve's size and class

Operation

- Model MN-770 is equipped with an adjustable flow pilot and an orifice assembly.
- The pilot senses the differential pressure across the orifice plate.
- Should this differential pressure rise above the pilot setting, the pilot throttles enabling pressure in the control chamber to accumulate, causing the main valve to throttle closed; thereby, limiting flow to the pilot setting.
- Should orifice differential pressure fall below the pilot setting, the pilot releases accumulated pressure and the main valve modulates open.
- Opening and/or closing speed can be set hydraulically using an opening and/or closing needle valve (optional)

Pilot Options

Various pilots and calibration springs are available. Select according to valve size and operation conditions. For more details check flow pilots (pressure reducing modified to differential sensing) product pages.



Adjustment Ranges	PSI	Bar
	3-25	0.2-1.7
	11-150	0.8-6.5

Pressure Rating

	Class 150			Class 300		
Max. Recommended Pressure	250 PSI			400 PSI		
Available End Connection	Flanged ANSI#150	Grooved ANSI/AWWA C606	Threaded	Flanged ANSI#300	Grooved ANSI/AWWA C606	Threaded

Materials

Components		Water Applications	Thermal Shock Applications	Base Solutions Applications	Acid Solutions Applications (**)
Main Valve	Body & Cover	Ductile Iron	Carbon Steel	Ductile Iron	Stainless Steel 316
	Internals	Stainless Steel	Stainless Steel	Stainless Steel	Stainless Steel 316
		Brass/Coated Steel	Brass/Coated Steel	Coated Steel	
	Elastomers	Synthetic rubber	Synthetic rubber	Synthetic rubber	Viton
Coating	Fusion Bonded Epoxy	Fusion Bonded Epoxy	Fusion Bonded Epoxy	Uncoated	
Pilot	Body	Brass/Bronze	Brass/Bronze	Stainless Steel 316	Stainless Steel 316
	Internals	Stainless Steel	Stainless Steel	Stainless Steel 316	Stainless Steel 316
		Brass	Brass		
Elastomers	Synthetic rubber	Synthetic rubber	Synthetic rubber	Viton	
Control Loop Accessories	Accessories	Brass/Bronze	Stainless Steel 316	Stainless Steel 316	Stainless Steel 316
	Orifice Plate	Stainless Steel	Stainless Steel	Stainless Steel	Stainless Steel 316
	Tubing & Fittings	Brass	Stainless Steel 316	Stainless Steel 316	Stainless Steel 316

(**) For highly aggressive acid solutions: Super Duplex, Hastelloy C-276, SM0-254 6-MO. Others by request.

Notes:

- Inlet pressure, outlet pressure and flow rate are required for optimal sizing and cavitation analysis.
- Recommended average flow velocity: 0.1-3.5m/sec; 0.3-11ft/sec. Intermittent flow velocity: 7.5m/sec-23ft/sec
- Minimum operating pressure: 0.7 bar / 10 PSI. For lower pressure requirements consult factory.

