



## Hydraulically Controlled Anti-Columning Deluge Valve with Local Reset Model FP 400Y - 5M

The BERMAD model 400Y-5M is an elastomeric, hydraulic, line pressure operated deluge valve, designed specifically for advanced fire protection systems and the latest industry standards.

The 400Y-5M is activated by a pressure operated relay valve, which latches the main valve open until locally reset. The 400Y-5M is ideal for systems with remote or elevated wet pilot lines, due to its boosted local pressure release. The optional valve position indicator can include a limit switch suitable for Fire & Gas monitoring systems.



(for Illustration Only)

### Benefits and Features

- **Safety and reliability**
  - Time proven, Simple, fail-safe actuation
  - Single piece, rugged, elastomeric diaphragm seal
  - VRSD technology
  - Obstacle-free, uninterrupted flow path
  - No mechanical moving parts
  - Latches open: remains open until reset locally
  - Valve position limit switches (optional)
  - Local valve position indicator beacon (optional)
- **High performance**
  - Very high flow efficiency
  - Minimal head loss: straight-through-flow Y-type body
  - Approved for PN25/365 psi
- **Designed for fire protection**
  - Face-to-face length standardized to ISO 5752, EN 558-1
  - Designed to meet the requirements of the industry standards
  - Opens quickly in systems with long wet pilot lines
- **Quick and easy maintenance**
  - In-line serviceable
  - Fast and easy cover removal
  - Swivel mounted drain valves\*

\* not including 1½" & 2" valves

### Typical Applications

- Remote or elevated wet pilot lines
- Automatic water spray systems
- Hydraulic remote controlled systems
- Automatic foam systems

### Approvals



UL-Listed  
Special System Water Control  
Valves, Deluge Type (VLFT)  
Sizes 1½" - 16"



FM Approved  
for Deluge Sprinkler Systems  
Sizes 1½" - 8"



Det Norske Veritas  
Type Approval



ABS  
American Bureau of Shipping  
Type Approval



Lloyd's Register  
Type Approval

### Additional Features

- Valve position limit switches
- Local valve position indicator beacon
- Alarm pressure switch
- Water motor alarm
- Sea water compatibility
- Drain valve/s inlet/outlet

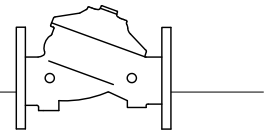

## Operation

(For illustration only)

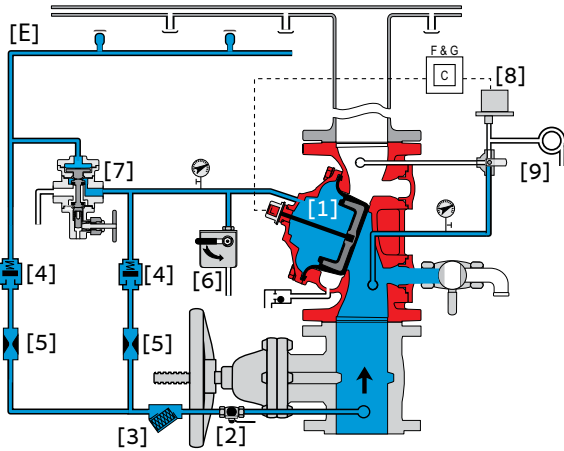

**Valve Closed** (normal conditions)

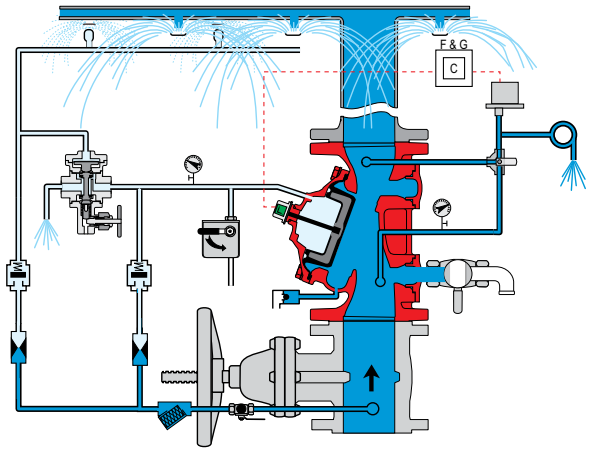

**Valve Open** (fire conditions)

The BERMAD model 400Y-5M is held closed by water pressure in the control chamber [1]. Upon release of pressure from the control chamber, the valve opens.

Under NORMAL conditions, water pressure is supplied to the control chamber via the priming line [2] and strainer [3], and a restriction orifice [5] and then trapped in the control chamber by a check valve [4], a manual emergency release [6], and a relay valve (URV-M) [7] that is held closed by hydraulic pilot line pressure [E]. The water pressure trapped in the control chamber holds the diaphragm against the valve seat, sealing it drip-tight and keeping the system pipes dry.

Under FIRE conditions, water pressure is released from the control chamber, either with the manual emergency release, or by the URV-M opening automatically in response to a decrease in hydraulic pilot-line pressure. This latches the 400Y-5M deluge valve open, allowing water to flow into the system piping and to the alarm device [9].

The URV-M is factory set to operate with a minimum pilot line elevation of 10 meters above the valve. Additional spring tension can be set to suit greater elevations, up to a maximum of 70 meters above the the valve (refer to the Valve Code Designation on the last page).

## System P&ID

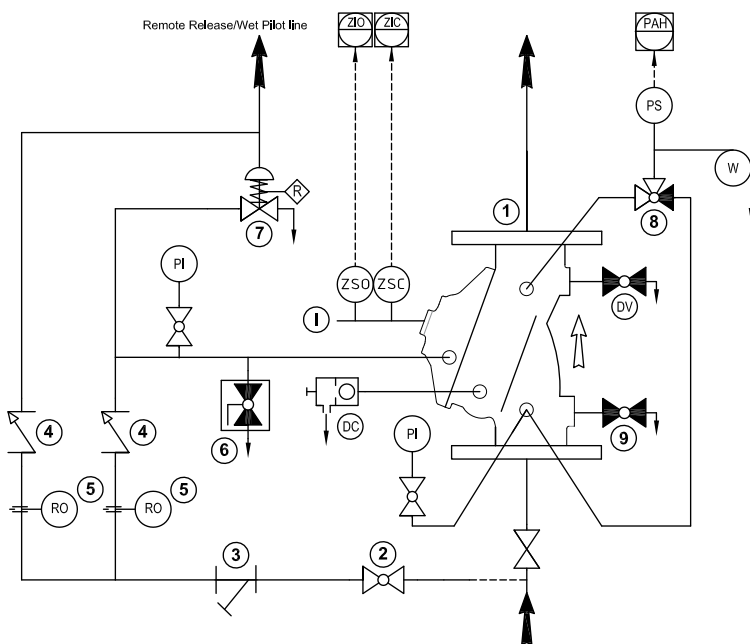

### Components

- 1 BERMAD 400Y Deluge Valve
- 2 Priming Ball Valve
- 3 Priming Strainer
- 4 Check Valve
- 5 Restriction Orifice
- 6 Manual Emergency Release
- 7 URV-2-M Relay Valve

### Optional System Items

- ZS Limit Switch Assembly
- I Visual Indicator
- DV Additional Drain Valve
- PS Pressure Switch
- W Water Motor Alarm
- PI Pressure Gauge\*
- DC Automatic Drip Check Valve\*
- 8 3-Way Alarm Test Valve\*
- 9 Main Drain Valve\*

See also Factory Fitted Options under the Valve Code Designations on the last page

\*Mandatory for FM approval  
(suffix A in code designations on page 4)





## System Installation

A typical installation of the BERMAD model 400Y-5M features automatic actuation via a pressure operated relay valve, triggered by a wet pilot line with closed fusible plugs elevated above the deluge valve. When open and fitted with a limit switch, the valve sends a feedback signal to the remote valve position monitoring system.

## Optional System Items



Water Motor Alarm



Pressure Switch



Valve Position Indicator



Limit Switch



Strainer

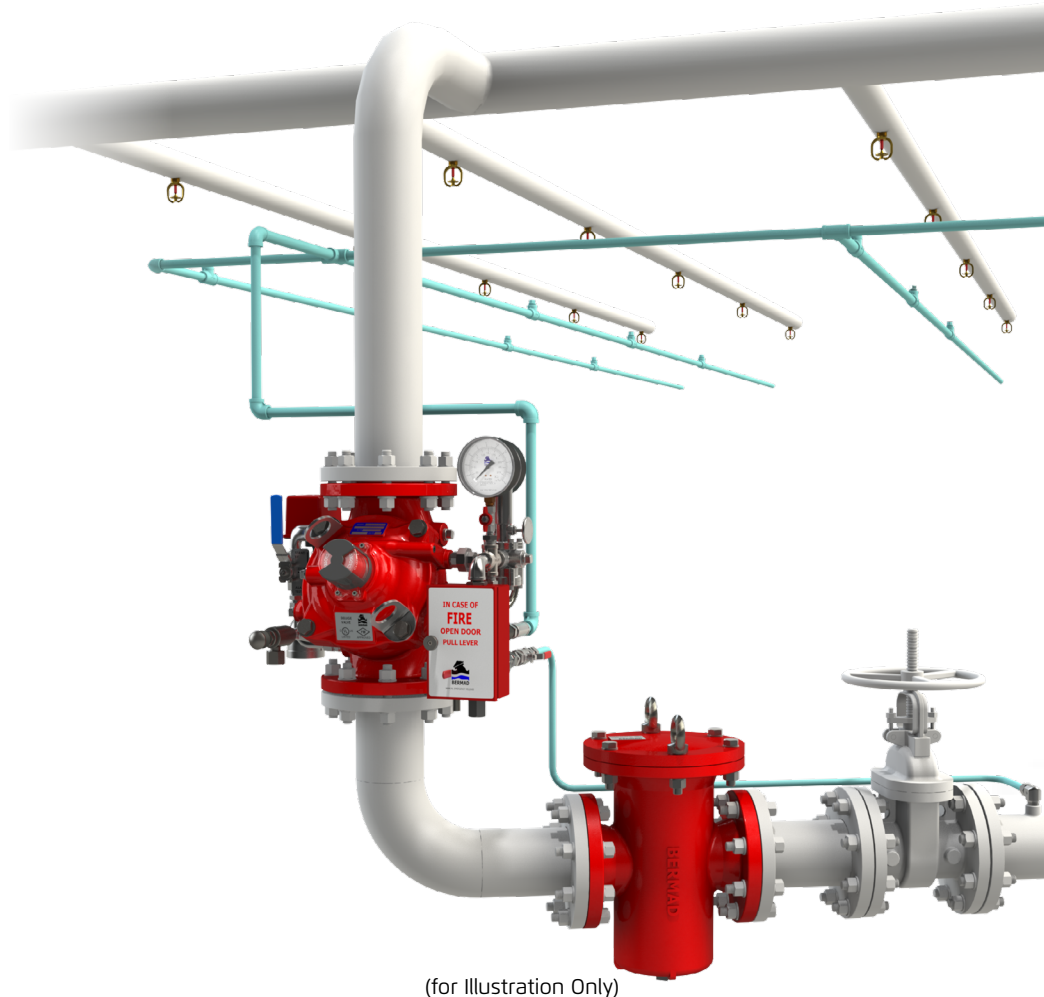

(for Illustration Only)

## Suggested Specifications

The deluge valve shall be a UL listed and FM approved, 25 bar/365 psi rated, elastomeric-type, straight-through, Y-type-body valve. The valve shall have an unobstructed flow path, with no stem guide or supporting ribs.

Valve actuation shall be accomplished by a one-piece, rolling diaphragm bonded with a rugged radial seal disk. The diaphragm assembly shall be the only moving part.

The deluge valve shall include a latching relay pilot valve, a Y-type strainer, a ball drain valve, an automatic drip-check with manual override, 4-inch pressure gauges, and a manual emergency release housed in a stainless steel box.

The valve drain socket shall be flanged and have 360-degree swivel.

The valve shall be equipped with a dual-color, rotational position indicator, readable from 50 meters, with two limit switches enclosed in a protective switch box. Removing the valve cover for inspection or maintenance shall not require removing the control trim. The deluge valve and its entire control trim shall be supplied pre-assembled and hydraulically tested by a factory certified to ISO 9000 and 9001 standards.



## Technical Data

### Available Sizes (inch)

- Flanged - 1½, 2, 3, 4, 6, 8, 10, 12, 14 & 16"
- Grooved - 1½, 2, 3, 4, 6 & 8"
- Threaded - 1½ & 2"

### Pressure Rating

- ANSI#150 - 16 bar / 235 psi
- ANSI#300 - 1½" to 10" 25 bar / 365 psi  
12" to 16" 20 bar / 300 psi
- Grooved/Threaded - 25 bar / 365 psi
- Minimum supply pressure is related to the the selected Pilot Trip Point setting, see notes 5 and 6 in code designations below

### Elastomer

- HTNR - Fabric Reinforced High Temperature Compound - See engineering data

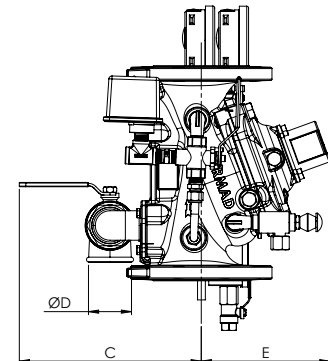
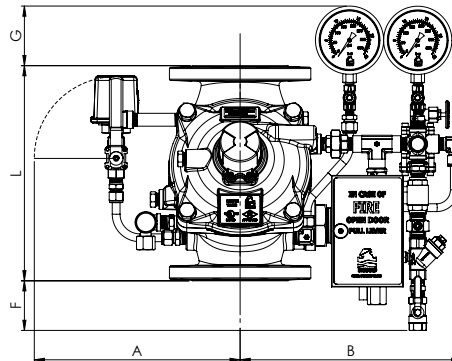

Valve Size	1½" DN40	2" DN50	3" DN80	4" DN100	6" DN150	8" DN200	10" DN250	12" DN300	14" DN350	16" DN400
<sup>(1)</sup> L <sup>1</sup> ANSI #150 mm (in.)	230(9.06)	230(9.06)	310(12.21)	350(13.79)	480(18.91)	600(23.64)	730(28.76)	850(33.49)	980(38.61)	1100(43.34)
L <sup>2</sup> ANSI #300 mm (in.)	230(9.06)	238(9.37)	326(12.84)	368(14.50)	506(19.94)	626(24.66)	730(28.76)	888(34.96)	980(38.61)	1100(43.34)
A mm (in.)	330(13.0)	330(13.0)	390(15.4)	398(15.7)	451(17.8)	481(18.9)	481(18.9)	594(23.4)	594(23.4)	594(23.4)
B mm (in.)	294(11.6)	294(11.6)	352(13.8)	362(14.3)	417(16.4)	445(17.5)	455(17.9)	568(22.4)	568(22.4)	568(22.4)
C mm (in.)	241(9.5)	241(9.5)	274(10.8)	290(11.4)	304(12.0)	320(12.6)	320(12.6)	383(15.1)	383(15.1)	408(16.1)
ØD	¾"	¾"	1½"	2"	2"	2"	2"	2"	2"	2"
E mm (in.)	167(6.6)	167(6.6)	191(7.5)	205(8.1)	273(10.7)	338(13.3)	338(13.3)	490(19.3)	490(19.3)	465(18.3)
F mm (in.)	179(7)	179(7)	109(4.3)	82(3.2)	0.5(0.02)	-	-	-	-	-
G mm (in.)	121(4.8)	121(4.8)	111(4.4)	98(3.9)	49.5(2)	25(1)	-	-	-	-
Kv m <sup>3</sup> /h (Cv gpm)	68(79)	80(92)	190(219)	345(398)	790(912)	1160(1340)	1355(1565)	2370(2737)	2850(3292)	3254(3758)
<sup>(2)</sup> Leq m (ft)	2(7)	5(16)	7(23)	9(30)	15(49)	27(89)	62(203)	52(171)	59(194)	88(289)
Weight, flanged kg (lbs)	17.7(39)	19.1(42)	33.8(74.4)	43.8(96.4)	87.1(191.6)	150.3(330.7)	180.3(396.7)	323.3(711.3)	356.3(783.9)	402.3(885)

Notes: <sup>(1)</sup> L1 Dimensions are for grooved, threaded and raised face flanged valves  
<sup>(2)</sup> Leq (Equivalent Pipe Length) refers to turbulent flow in new steel pipe schedule 40, values given for general consideration only  
<sup>(3)</sup> Dimensions for the trim envelope may vary with specific component positioning

## Valve Code Designations

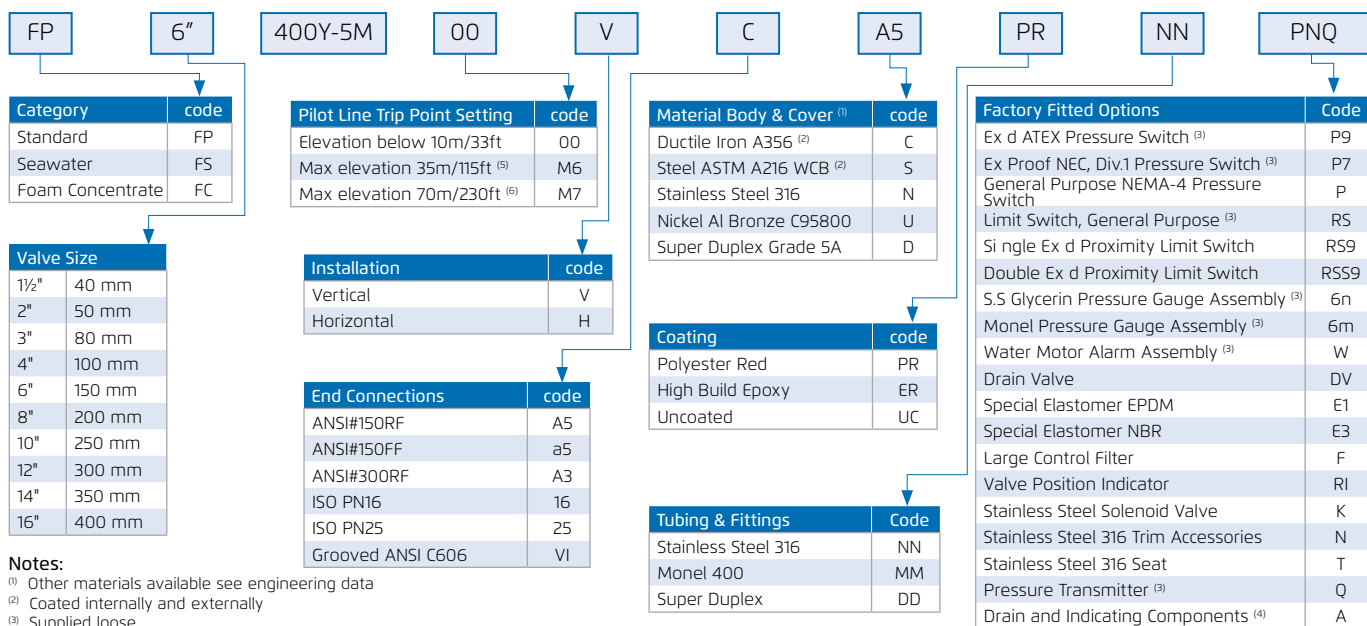

Notes:  
<sup>(1)</sup> Other materials available see engineering data  
<sup>(2)</sup> Coated internally and externally  
<sup>(3)</sup> Supplied loose  
<sup>(4)</sup> Mandatory for FM approved valves  
<sup>(5)</sup> Minimum supply pressure to the Deluge Valve shall be at least 5.0 barg  
<sup>(6)</sup> Minimum supply pressure to the Deluge Valve shall be at least 8.5 barg

